

# Great Balls a' Fire

**RULES:** Practical Shooting Handbook, Latest Edition      **COURSE DESIGNER:** Brad Sitton

**START POSITION:** Standing in Box A hands naturally at sides

### STAGE PROCEDURE

On audible start, engage all targets as they become visible  
From behind the charge lines

### SCORING

**SCORING:** Comstock, 24 rounds, 120points  
**TARGETS:** 10 IPSC, 4 PL  
**SCORED HITS:** Best per IPSC, steel down = 1A  
**START-STOP:** Audible - Last shot  
**PENALTIES:** Procedural. -10  
 No-shoot hit. -10  
 Miss. -10

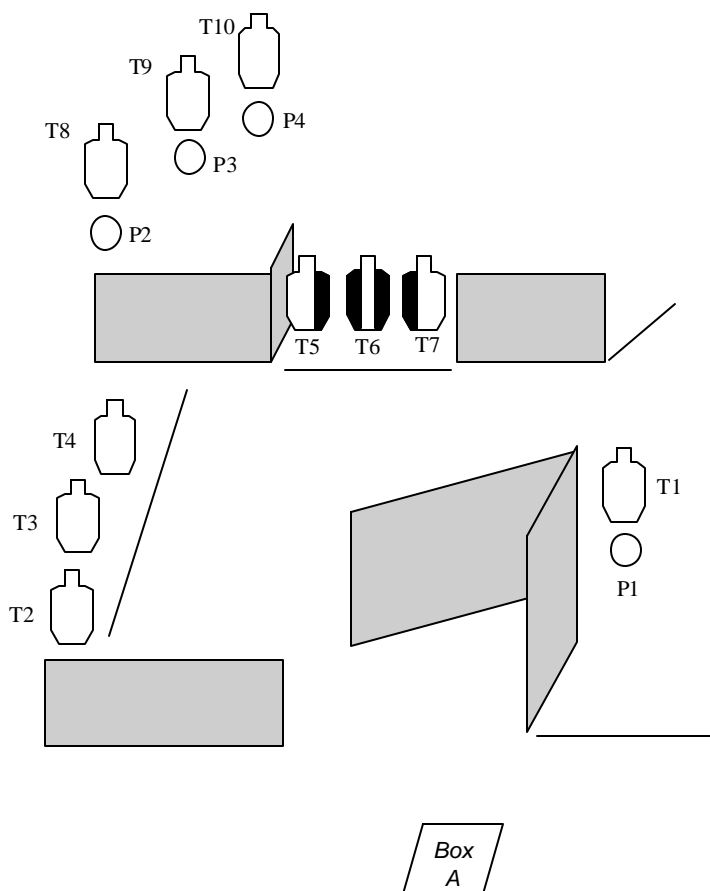

**SETUP NOTES .:**

**RO NOTES :**